

## DESIGN AND DEVELOPMENT TRENDS IN MODERN DRILLING TOOLS: A REVIEW

A. Lewandowska, M. Salamon, K. Leksycki\* and E. Feldshtein  
Faculty of Mechanical Engineering, University of Zielona Góra,  
4 Prof. Z. Szafrana Street, 65-516 Zielona Gora, POLAND  
E-mail: k.leksycki@iim.uz.zgora.pl

Drilling is one of the most common machining operations, and its capabilities are utilized on lathes, drilling machines, conventional milling machines, as well as various CNC machines. This paper provides an overview of modern drill bit designs and current trends in their development. The study considers twist drills, three-flute drills, drills with indexable inserts, step drills, solid carbide drills, and other types of drills widely used in industry. The rationale for this review is to systematize knowledge of existing solutions and to highlight the factors affecting drill performance, including material, design, and manufacturing precision. The review is based on an analysis of selected peer-reviewed publications, including both classical references and recent studies, chosen according to their relevance to drill design, performance, and manufacturing aspects. The review identifies dominant development trends, research gaps, and technological challenges that require further investigation. Special attention is given to drill bit geometry, cutting parameters, and design modifications aimed at improving tool life, machining efficiency, and hole quality, as well as reducing production costs.

**Key words:** drilling tools, drill bit design, drill geometry, cemented carbide drills, indexable insert drills

### 1. Introduction

Drilling is a machining process used to create holes in solid materials. The basic tools employed in this process are drill bits with a defined diameter and length, which are used to produce either through holes or blind holes. Kiyak [1] determined, based on an assessment of the number of operations used in machining, that drilling accounts for approximately 33% of all machining operations. During drilling, the drill performs both the main cutting motion and the feed motion, and during operation it is aligned with the axis of the hole. Drilling is a complex process in which high loads are applied to the cutting edges at variable cutting speeds.

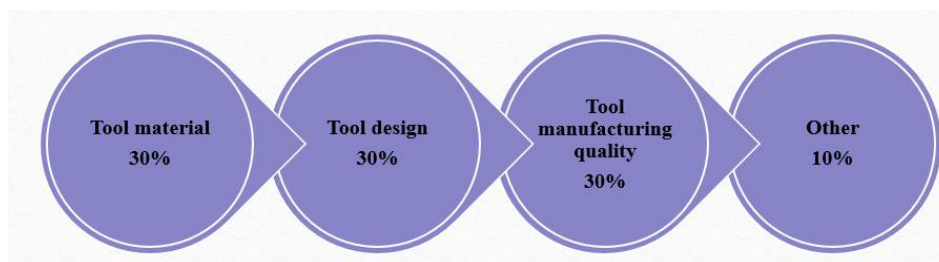

Fig.1. Influence of basic indicators on the quality of manufactured drills (according to Astakhov [3]).

Chip evacuation is difficult, particularly when machining deep holes. In addition to cutting forces, radial and axial forces act on each cutting edge. Drills operate under severe conditions, characterized by significant loads on the cutting edges and varying cutting speeds. Moreover, drill bits exhibit relatively low

---

\* To whom correspondence should be addressed

torsional and bending rigidity [2]. According to Astakhov [3], the quality of drill bits depends on the basic indicators presented in Fig.1.

Using a systemic approach, a drill, like any tool, can be considered part of a larger system (Fig.2), which includes the machine tool, the tool holder, the work-piece, the work-holding device, the technological medium, the machining parameters, and the control systems.

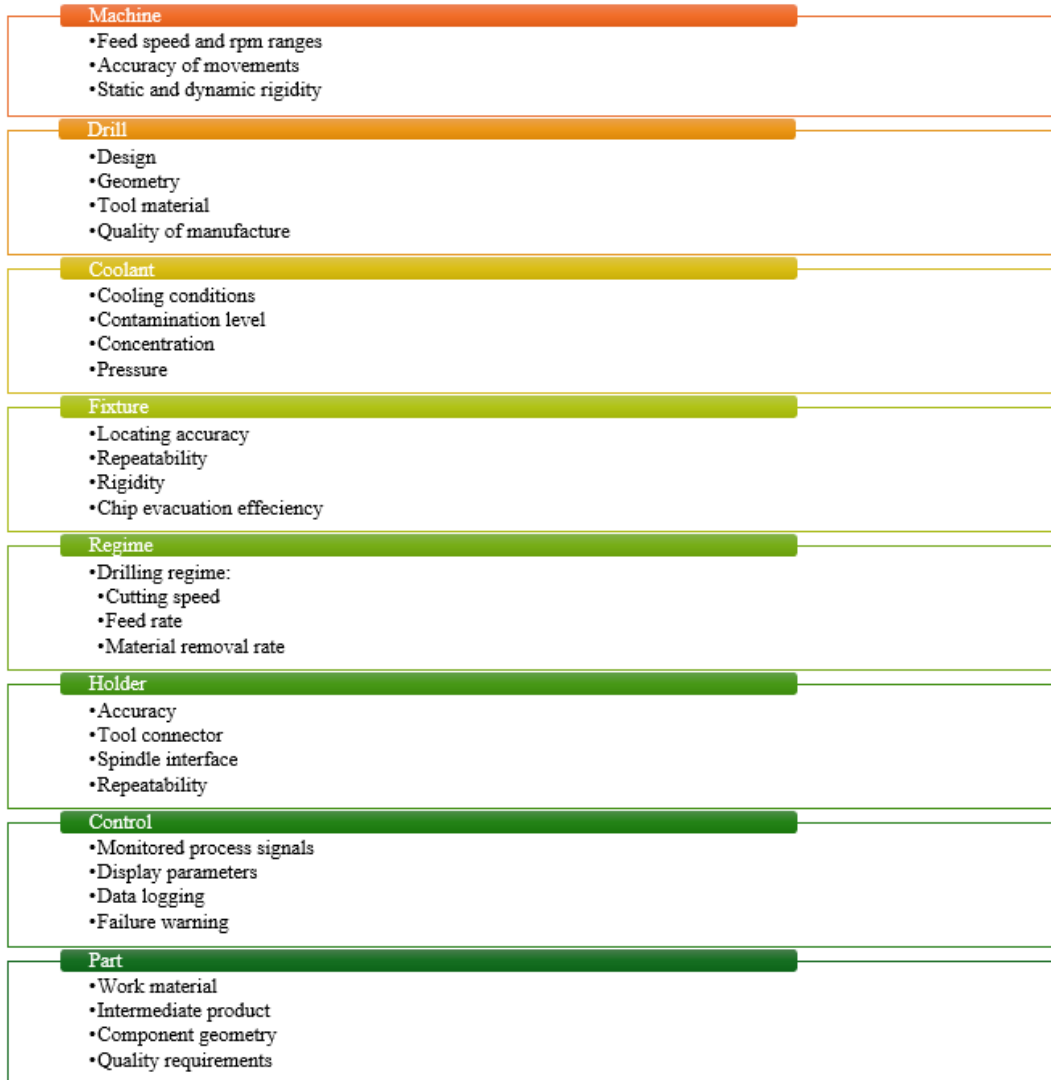

Fig.2. Components of the drilling system (according to Astakhov [3]).

All components of the system must be consistent with each other, forming a coherent unit. Poor quality in any component will result in a lower overall quality of the drilling process. During the production of drill bits, it is impossible to achieve a perfectly sharp cutting edge. At the micro-scale, the contact surface between the tool, the chip, and the work-piece is irregular and jagged. To mitigate these surface irregularities, the tool must be properly prepared to extend its service life and improve the quality of the machined surface of the work-piece. According to Astakhov [3], investing in higher-performance, more expensive tools yields significantly greater benefits than saving on the purchase cost of drills.

This review article presents the design and development trends in modern drilling tools. In contrast to existing review articles, which typically focus on selected aspects of drilling such as cutting parameters, tool wear, or specific tool types, this study provides a comprehensive perspective on the design and development

trends in modern drilling tools. Particular emphasis is placed on the evolution of drill geometry, structural solutions, and material developments, as well as their combined influence on machining performance and hole quality. The presented approach integrates both scientific findings and industrial solutions, enabling the identification of current development directions and existing research gaps. This contributes to a better understanding of the relationships between tool design, manufacturing precision, and operational performance in drilling processes.

## 2. Drill bit characteristics and drilling process

For many decades, the most common type of drill bit has been the twist drill, characterized by two helically arranged flutes terminating in cutting edges. Currently, drill bits with diverse designs, flute geometries, materials, and coatings are used to enhance their efficiency, durability, and dimensional and shape accuracy.

### 2.1. Drill bit classification

The basic criteria for classifying drill bits include general construction, the material of the working part, the number of cutting edges, protective coatings applied to the cutting edges, shank design, and the method of supplying the cutting fluid. Currently, drills are manufactured from high-speed steel, carbide, ceramic materials, and diamond-sintered materials. In terms of general construction, drills can be solid, with the working part permanently bonded, or assembled [4].

Twist drills differ in blade geometry, chip formation and removal methods, cooling methods, and the possibility of replacing cutting elements. In industrial practice, three-flute solid carbide drills with internal channels for supplying the process medium, coated drills, drills with replaceable inserts, multi-stage drills, and special-purpose drills are increasingly being used [5].

New drill designs are developed with the requirements of increasingly faster production in mind, which necessitates enhanced machining efficiency and tool durability [6]. Industrial development also demands savings in time and material resources, which has led to modern drill designs incorporating replaceable tips or plates, as well as modular or folding tools. The use of such drills results in reduced machine changeover time, increased machine productivity, and lower production costs [7].

Given the rising demands placed on modern hole-making tools, drill bits are undergoing significant design developments, leading to a wide variety of solutions tailored to machining conditions, work-piece material, expected machining quality, and other factors. Nowadays, great emphasis is also placed on sustainable development, including the reduction of waste and minimization of energy consumption in manufacturing processes, which impacts both the economy and the environment [8].

### 2.2. Drilling parameters and twist drill design

Until now, twist drills have remained the most commonly used and purchased tools for hole machining. They are considered universal drills due to their functional yet simple design and geometry, which ensures effective shaping of the machined surface [10].

One of the cutting parameters in drilling operations (Fig.3) is the cutting speed ( $v_c$ ), calculated using Eq.(2.1), where  $d$  is the drill diameter in millimeters and  $n$  is the rotational speed in revolutions per minute. If both the work-piece and the drill rotate in opposite directions, the rotational speed is taken as the sum of the rotational speeds of the drill and the work-piece.

$$v_c = \frac{\pi dn}{1000} \left[ \frac{m}{min} \right]. \quad (2.1)$$

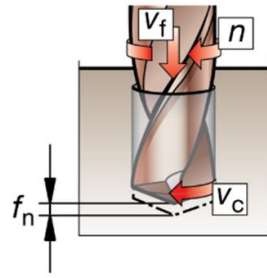

Fig.3. Drilling parameters [11]:  $f_n$  – feed per revolution,  $mm/rev$ ;  $v_c$  – cutting speed,  $m/min$ ;  $v_f$  – feed rate,  $mm/min$ ;  $n$  – spindle speed,  $rpm$ .

The next drilling parameters are the feed rate  $f_n$ , i.e., the distance the drill advances into the material during one full rotation (Eq.2.2), and the feed per cutting edge  $f_z$ , i.e., the portion of the feed rate per cutting edge, described by Eq.2.3, where  $z$  is the number of cutting edges.

$$f_n = \frac{v}{n}, \quad (2.2)$$

$$f_z = \frac{f_n}{z}. \quad (2.3)$$

Selecting the appropriate cutting parameters during drilling is crucial to reduce wear on drill bits and to enhance drilling efficiency by minimizing the cost per hole. Excessively high cutting speeds and feed rates can lead to reduced efficiency and tool breakage. Proper work-piece clamping is also essential, as incorrect fixation can cause self-excited vibrations and displacement of the work-piece under cutting forces, resulting in reduced tool life, lower accuracy of the machined surface, and drill breakage [3].

The drill consists of three basic parts, A, B, and C (Fig.4), which are, respectively, the body (working part), the shank, and the connecting part (also called the neck) [4].

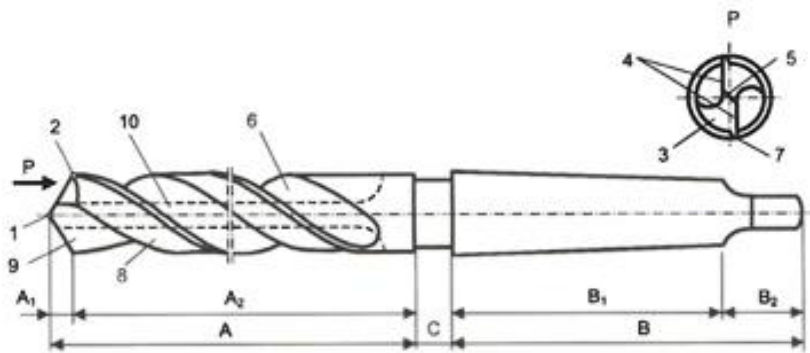

Fig.4. Construction of a twist drill [4]: 1 – point, 2 – outer corner, 3 – primary flank, 4 – main cutting edges, 5 – chisel edge, 6 – flute, 7 – margin, 8 – secondary flank, 9 – rake face, 10 – web; A – working part, B – shank, C – neck; A1 – cutting part, A2 – guiding part; B1 – Morse taper, B2 – tang.

The working part of the drill bit includes the main cutting edges, which ensure proper material removal; the chisel edge, which removes material in the central part of the hole and generates the highest axial loads; the margin, acting as minor cutting edges (blade contact surfaces), which guide the drill bit in the hole, stabilize

the tool, and minimize friction; and the core, which, as the central part of the drill bit, provides its rigidity [4]. In addition, the working part also includes flutes, which simultaneously enable chip evacuation and the supply of cutting fluid to the cutting zone. The helix angle of the flute influences chip formation and cutting performance [12]. The shank secures the drill in the tool holder or spindle nose. Depending on the drill diameter, cylindrical shanks, Morse taper shanks, and special shanks are used. The connecting part, also known as the neck, links the working part to the shank [13].

### 2.3. Drill geometry

The basic parameters of drill geometry are shown in Fig.5. The minor cutting edge is located at the end of the core and connects the main cutting edges, while the web tip angle is defined as the angle between the web tip and the cutting edge when viewed perpendicular to the drill front. The web tip is responsible for approximately 60% of the total axial force. Highly negative rake angles on both parts of the chisel edge face can cause excessive deformation of the material during chip formation; however, if the clearance angles are sufficiently large, this does not create problems during drilling. There are two approaches to increasing the rake angle: extensive, in which the appropriate tool flank face shapes are used, and intensive, which involves modifications to the contact between the chip and the flank face [11].

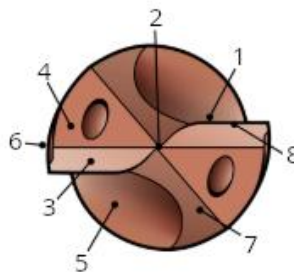

Fig.5. Drill point geometry [11]: 1 – main cutting edge, 2 – chisel edge, 3 – primary flank, 4 – secondary flank, 5 – flute, 6 – margin, 7 – tertiary flank, 8 – main cutting edge chamfer with negative rake angle.

In a conventional drill bit (Fig.6a), a web is formed, whereas in a multi-flute drill bit (Fig.6b), two or more cutting surfaces are formed at different angles, which reduces the required axial and friction forces.

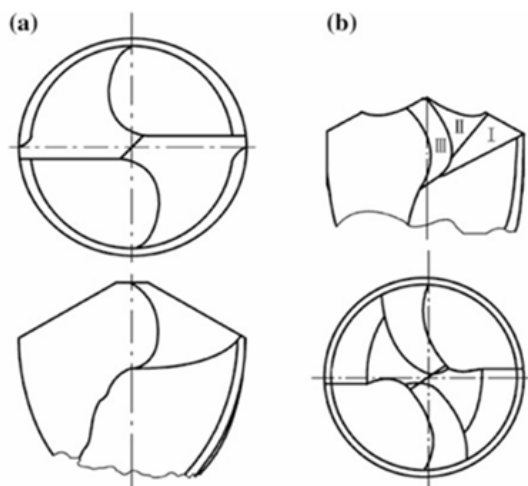

Fig.6. Twist drill: a) conventional, b) multi- flute

According to DIN 1412:2001-03 (Fig.7), there are many types of drill point geometries. In engineering practice, Form *N* and Form *C* drill bits are most commonly used. The choice of a specific drill type depends on various factors. In Form *A* drills, the cutting edge is approximately 8% of the diameter in width; Form *B* allows for correction of cutting edge run out and adjustment of the rake angle; Form *C* (also known as the split point) is used for drills with large core diameters; Form *D* has corners that prevent material from chipping when exiting the hole, thereby limiting burr formation at the exit; Form *E* is primarily used for sheet metal processing; and Form *S*, usually combined with a parabolic flute, represents a special type of grinding [14]. To control chip shape, facilitate chip breaking, and ensure efficient chip removal from the cutting zone, modifications such as separating grooves along the length of the flute, adjustments to the rake face immediately behind the cutting edge, and flutes on the rake face for improved chip breaking are employed. The use of cutting edges with protrusions increases the rigidity of the formed chip, further facilitating its breaking.

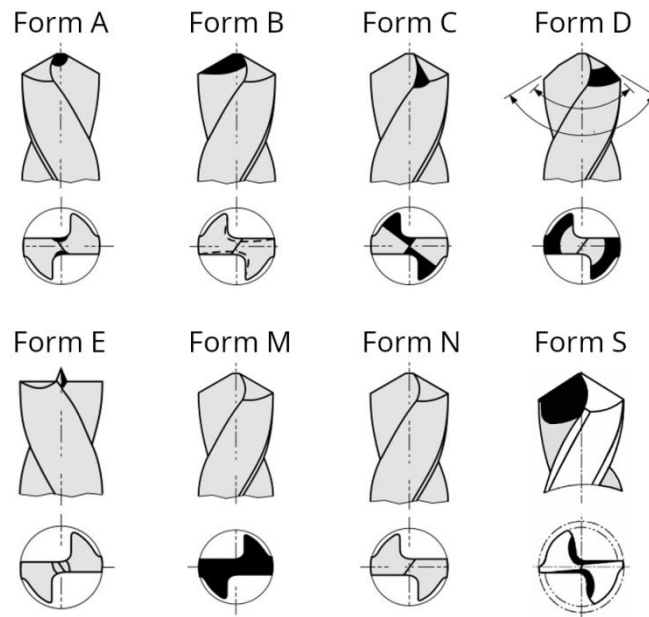

Fig.7. Drill point sharpening types according to DIN 1412: Form *A* – thinned chisel edge; Form *B* – conical ground surface with thinned chisel edge and corrected cutting lip; Form *C* – conical ground surface with split point; Form *D* – conical ground surface, faceted point; Form *E* –  $180^\circ$  point angle with centering tip; Form *M* – micro-drills; Form *N* – conical ground surface; Form *S* – special grind

The point angle is defined as the angle between the cutting edges. A smaller point angle results in a longer cutting edge, which can increase tool life by reducing its rigidity. The point angle is selected depending on the material being machined. As a standard, for soft materials it is  $80-90^\circ$ , for cast iron and steel  $116-118^\circ$ ,

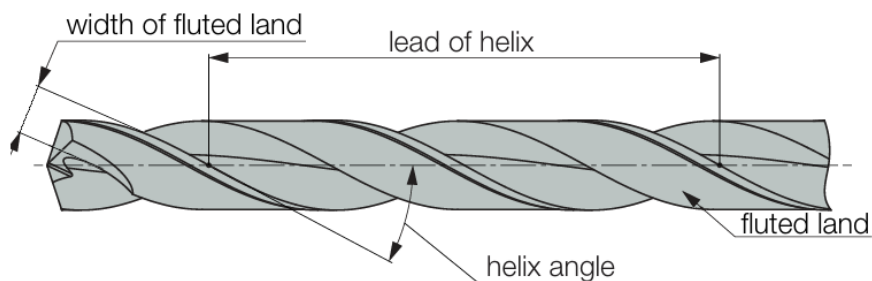

Fig.8. Fluted land (according to ISCAR)

and for hard steels  $130\text{-}140^\circ$ . The helical part covering the margin and flank faces is referred to as the flute face, and the distance between the minor cutting edge of the margin and the heel, measured at a right angle to the minor cutting edge, defines the width of the flute face (Fig.8). The web tip is the central part of the drill located between the flute bottoms along the length of the flute, and its thickness is measured as the minimum dimension of the web in the plane perpendicular to the drill axis.

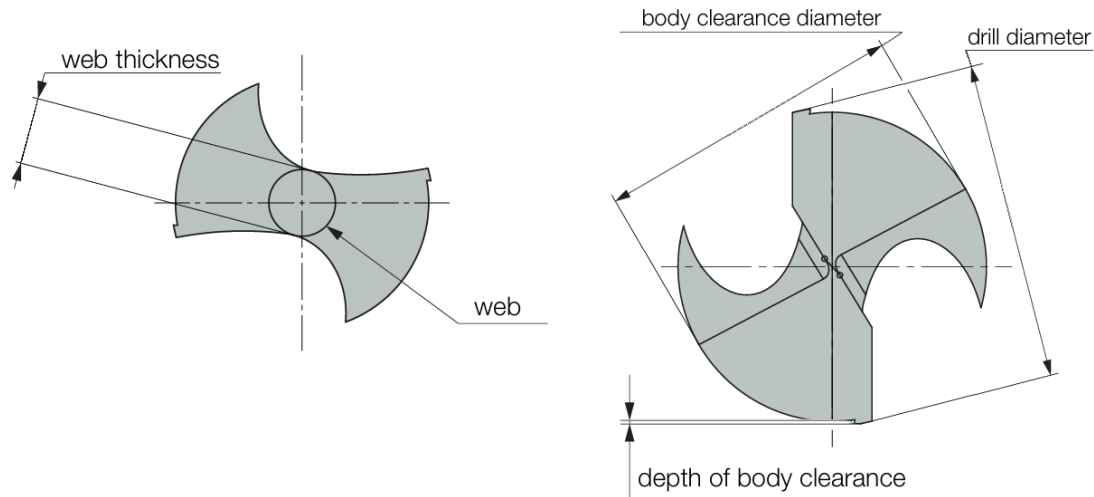

Fig.9. Web thickness (a) and body clearance (b); (according to ISCAR)

The margin is the peripheral part of the drill blade and body located between adjacent flutes. The width of the margin is defined as the distance between the leading edge and the heel of the margin, measured at a right angle to the leading edge (Fig.10). The edge formed by the intersection of the margin and the flute is referred to as the flank leading edge, or secondary cutting edge. The drill diameter is measured at the flanks of the drill at the circumferential corners. The back surface is the part of the side surface of the drill with a reduced diameter relative to the flank, providing diametric clearance. The cylindrical part of the flank is an unground leading flank that ensures clearance (Fig.10) [15].

The tip of the drill consists of chip-forming elements, primarily the major cutting edges, rake faces, and flank faces (Fig.10). The flank face at the drill tip is bounded by the major cutting edge, the flute margin, the flute, and the web. The flank face forms a recess (Fig.9), which serves as a basis for subsequent recesses, such as the major flank, designed to provide clearance for the edges and to prevent interference between the flank face and the bottom of the drilled hole. The rake face is the portion of the fluted land adjacent to the major cutting edge along which the chip produced during drilling moves. The cutting edge extends from the peripheral corner of the drill to its center; in a double-flute drill, the cutting edges extend from the shear zone to the circumference. The cutting edge is the part located between the rake face and the flank face associated with the major cutting edge [15].

The flute lead is defined as the axial advance of the helical line per full revolution, or the distance between two consecutive points where the helical line is tangent to a line parallel to the drill axis. The peripheral rake angle is the angle between the leading edge of the margin and the axial plane at the drill tip. The rake angle is defined as the angle between the tangent to the helical leading edge and the plane containing the drill axis and the tip. It is formed between the rake surface and the plane passing through a point on the cutting edge and the drill axis. The orthogonal clearance angle of the major cutting edge is the angle between the flank face and the plane containing the cutting edge and the assumed direction of the main cutting motion at a selected point on the edge. The normal rake angle is the angle between the flank face and the plane passing through a point on the cutting edge and the drill axis. The normal angle of the major cutting edge is the angle between the flank face and the plane containing the cutting edge and the assumed direction of the main cutting motion at a selected point on the edge [15].

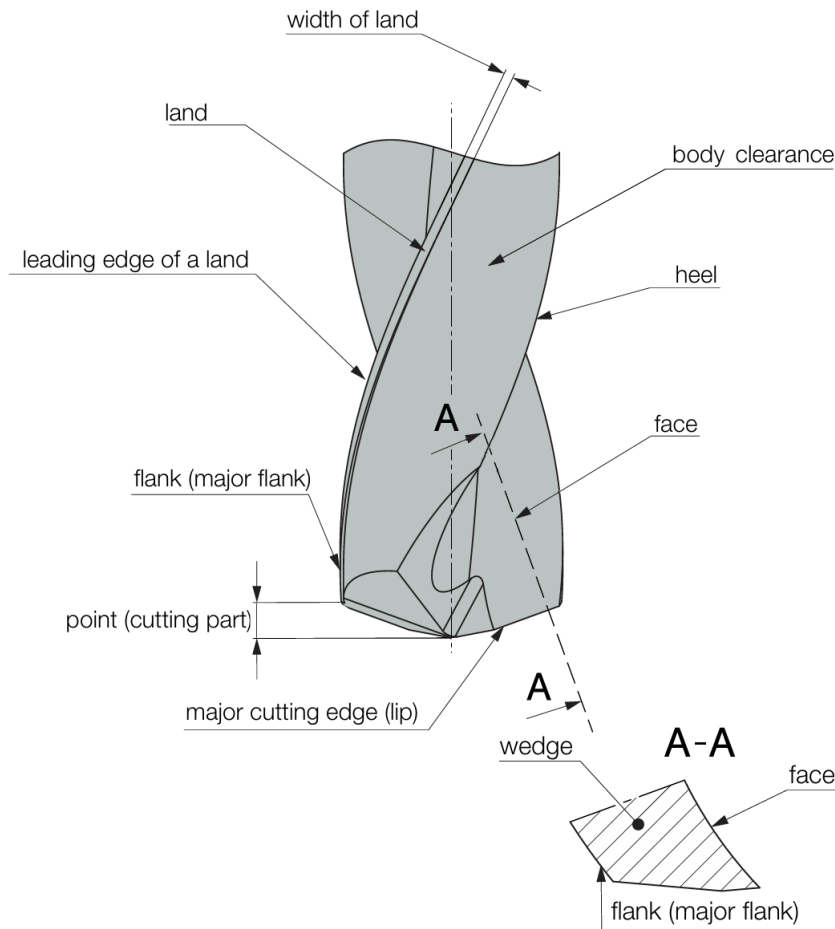

Fig.10. Elements of drill geometry (according to ISCAR).

The selection of an appropriate drill bit depends on the material being machined, the required hole quality, drilling depth, and the cutting parameters employed. Depending on the machinability of the material, the desired hole accuracy, the rigidity of the drill core, and the drill material, drills with geometries that facilitate chip removal, internal cooling, or special coatings are used. Moreover, depending on the cutting parameters, different core diameters, protective coatings, or modified cutting edges may be employed to reduce axial forces [16,17].

### 3. Cemented carbide drills

Cemented carbide drill bits are made of sintered carbide and typically feature a two- or three-flute design. They may also include internal channels for supplying the cutting fluid during operation [5]. Sintered carbide is characterized by high hardness, reaching up to  $1800\text{ HV}$ , excellent wear resistance, and high-temperature stability. Cemented carbide drills are manufactured using powder metallurgy, and cemented carbides consist of tungsten, titanium, and tantalum carbides with cobalt as the binder phase. The cobalt content in cemented carbide varies from 2% to 16%, depending on the grade.

Sintered carbides can be classified according to particle size: coarse-grained carbides ( $3\text{-}30\ \mu\text{m}$ ), standard carbides ( $1.5\text{-}3\ \mu\text{m}$ ), fine-grained carbides ( $0.5\text{-}1.5\ \mu\text{m}$ ), ultra-fine-grained carbides ( $\leq 0.5\ \mu\text{m}$ ), and nano-grained carbides ( $\leq 0.2\ \mu\text{m}$ ). Cemented carbide drill bits can also be manufactured from so-called gradient materials, which exhibit variations in properties due to changes in chemical composition or heat treatment. A drill bit made of gradient material is shown in Fig.11 [2, 4].

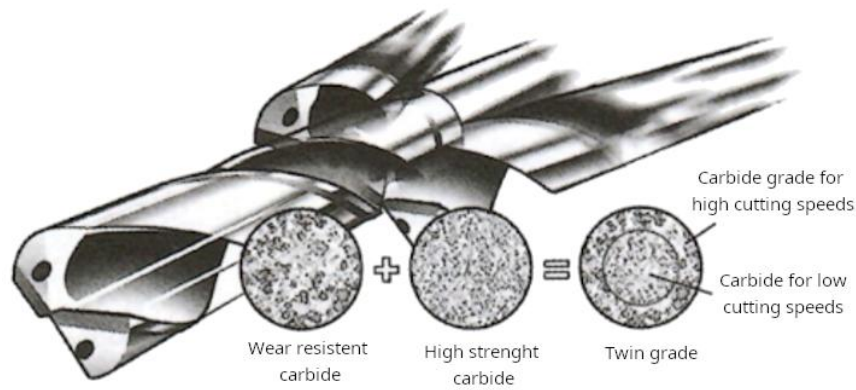

Fig.11. Schematic of a drill made of functionally graded material (FGM) [4].

The main advantage of cemented carbide drill bits is their high wear resistance, which can be up to 60% greater than that of HSS drill bits. They also exhibit excellent high-temperature resistance, which is particularly important for high-speed drilling. The primary disadvantage of cemented carbide drills is their brittleness, which increases the risk of cracking or breakage during operation. Additionally, cemented carbide drills are associated with a high unit cost, and the use of internal channels for supplying cutting fluid further increases the financial outlay. Cemented carbide drills are employed in industry for machining applications in the aerospace, automotive, defense, medical, oil and gas, energy, and renewable energy sectors [18]. Primarily, they are used for machining hard and difficult-to-machine materials, as well as in series production (Fig.12) [19].



Fig.12. Cemented carbide drills [20].

#### 4. Three-flute drills

The current trend in drill development is to increase the number of cutting edges from the traditionally used two-edged twist drills to three-edged drills (Fig.13). The addition of a third cutting edge significantly enhances the material removal rate, as the extra blade allows for an approximate 33% increase in feed per revolution. Compared to two-flute drills, the design of three-flute drills provides more favorable conditions for chip formation and efficient chip evacuation due to the larger chip spaces. Improved chip evacuation reduces heat generation, particularly at high cutting speeds.

The increased number of cutting edges, compared to conventional twist drills, allows for a more even distribution of cutting forces, minimizing shape deviations and reducing surface roughness. Three-flute drills feature a corrected flank face near the web, enabling drilling without pre-drilling [4, 5]. The corrected flank face, formed at the point where the blades converge with the transverse surface, reduces the width of the flank face or alters the clearance angle, thereby reducing friction and improving shape accuracy. Three-flute drills are available with diameters  $D$  ranging from 4 mm to 20 mm and working lengths of 3-12  $D$ . These drills are preferred over four- or five-flute designs, as increasing the number of flutes would narrow the chip spaces, complicating chip removal [4].



Fig.13. MAPAL three-flute drill [20].

Three-flute drills contribute to lower surface roughness in holes compared to two-flute drills. They can operate at high cutting speeds and are suitable for machining difficult-to-machine materials, such as aluminum alloys and stainless steel. Three-flute drill bits are commonly used in the aerospace industry to achieve the required dimensional and geometric accuracy [21].

## 5. Indexable insert drills

Indexable insert drills are widely used in hole machining (Fig.14). These drills may feature straight or helical flutes and are also employed for machining bosses, counterboring, spot facing, and turning operations [2, 5]. Most drills include channels for supplying cutting fluid during operation.

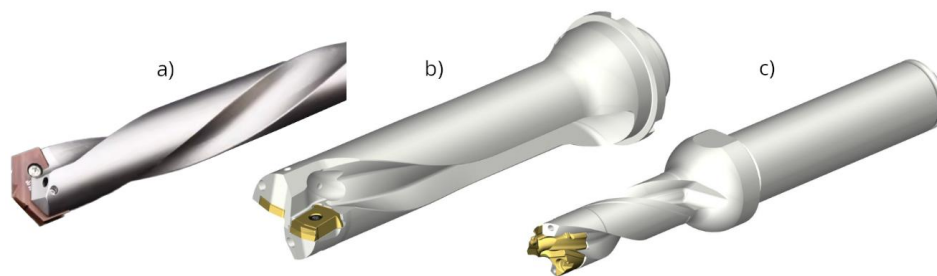

Fig.14. Drills with indexable inserts: a) drill with an exchangeable blade [22], b) indexable insert drill [23], c) drill with an exchangeable head [23].

Indexable insert drill bits are available in two variants: with an exchangeable tip or with indexable cutting inserts. There are two types of replaceable tips: a single-blade tip or a complete drill tip [4]. The tips can be mounted in the body using various methods, including a threaded shank (Fig.15a), an exchangeable blade (Fig.15b), or a clamped head (Fig.15c).

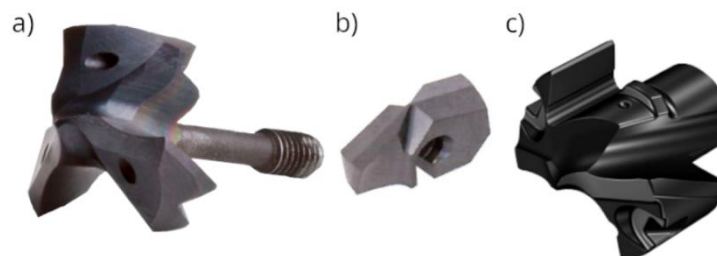

Fig.15. Exchangeable drill heads: a) with a threaded shank [24], b) exchangeable blade [22], c) clamped head [23].

Indexable insert drill bits for holes with diameters of 20-60 mm typically have two inserts, while larger hole diameters are machined using drills with four inserts. The inserts can be mounted directly in the tool body or via an insert cartridge and are positioned asymmetrically relative to the drill axis, ensuring that the radial load is evenly distributed on both sides. The advantages of this design include high efficiency and the possibility of rapid replacement of worn inserts [2, 5].

An example of a drill with indexable inserts is shown in Fig.16. This drill features three major cutting edges formed by the insert arrangement illustrated in Fig.16. During drilling, the inserts do not cut the entire bottom surface of the hole; at the points where the cutting edges are interrupted, a core is formed, which is removed by the chip and evacuated by the cutting fluid supplied through the channels (C) in the drill body [2]. Designs of drilling inserts are shown in Fig.17.

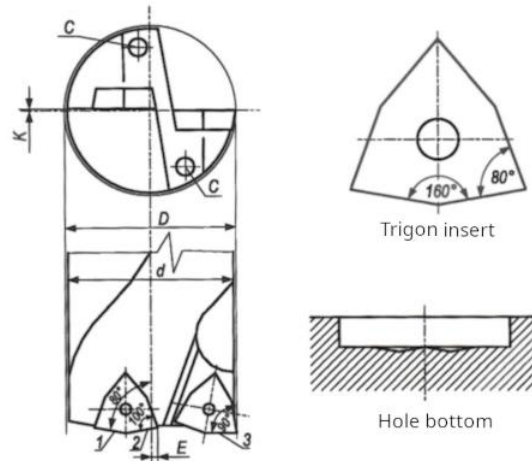

Fig.16. Example of an indexable insert drill construction [2].

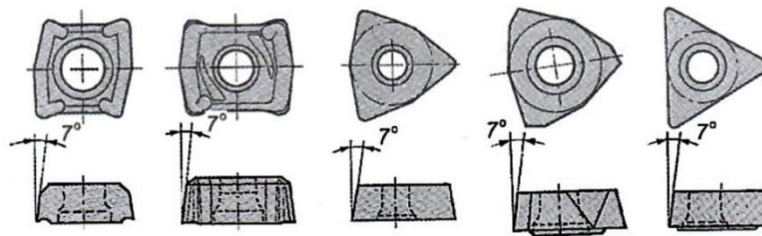

Fig.17. Designs of indexable drilling inserts [5].

Both indexable inserts and exchangeable tips are typically made of cemented carbide, providing high hardness and wear resistance, while the drill bodies are made of steel or high-strength steel. This design reduces machining costs by allowing the insert or tip to be replaced rather than the entire drill bit [25]. The same drill body can be combined with different insert designs, increasing the versatility of the tool. Drills with replaceable inserts enable the machining of very deep holes [26]. The use of internal channels for supplying cutting fluid, combined with a body design that reduces flow resistance and delivers the fluid close to the cutting edges, improves cooling and ensures efficient chip evacuation, contributing to increased tool life. Furthermore, the replaceable elements must be tightened with the correct torque to precisely set the geometry, which affects the dimensional and geometric accuracy of the hole. Although drills with indexable inserts offer high performance, monolithic drills provide better dimensional and geometric accuracy and lower surface roughness. Indexable insert drills are mainly used in large-scale and serial production, for machining difficult-to-machine materials and deep holes. Drilling with replaceable inserts ensures high dimensional accuracy and is widely employed in serial production, particularly for steel, cast iron, and aluminum alloys.

## 6. Step drills

Step drills (Fig.18) are widely used in high-performance manufacturing because they can drill holes with multiple diameters, allowing a hole with a screw head surface, milling, or threading to be produced in a single operation. In addition, step drills are suitable for machining a wide range of materials, from aluminum alloys and structural steels to cast iron, plastics, laminates, and composites [5, 27].



Fig.18. Step drills: a) two-step [23] and b) multi-step [28]

Step drills can be categorized into spiral drills with two or three blades, step drills with two straight blades, and multi-margin step drills. Cone step drills feature a smooth transition from the smallest to the largest diameter, while multi-step drills are designed with a pilot step followed by a working step, where the first step serves as a centering device and the subsequent step produces the final diameter. Step drills may also incorporate internal channels for supplying cutting fluid. The most commonly used tool materials for these drills are HSS, HSS-Co, and cemented carbide, and TiN and TiAlN coatings are also applied.

Multi-step drills are primarily used for drilling holes in thin steel and aluminum sheets, composites, and plastics. They are widely employed in the sheet metal and installation industries. Step drills can be used for both dry and wet machining, and the application of appropriate tool coatings enables the machining of stainless steel. The main advantage of step drills is their efficiency, as a stepped hole can be produced with a single tool. Step drills are also used for reaming and deburring existing holes. Hole quality is generally higher when drilling thinner materials, as deeper holes increase the risk of inadequate chip evacuation, leading to higher cutting forces [29].

## 7. Further development of hole-processing tools

The designs of modern drills are continuously being improved, with research focused on developing the most economically and environmentally viable tools. Modifications to existing drills aim to increase wear resistance, enhance chip evacuation during machining, and optimize hole accuracy and surface finish. Pelikan *et al.* [30] examined the geometry of a modified twist drill and a twist drill with an additional chip breaker (Fig.19). Modifications to twist drills were also analyzed by Jeong *et al.* [31], who introduced additional grooves along the flute to improve chip evacuation by reducing adhesion and friction on the flute face. Oztrük *et al.* [32] optimized the twist drill by creating a square cross-section texture on the rake face, which increased drilling efficiency (Fig.20). Maldonado-Cortes *et al.* [33] investigated surface structures on twist drills, including micro-square texturing and micro-channels.

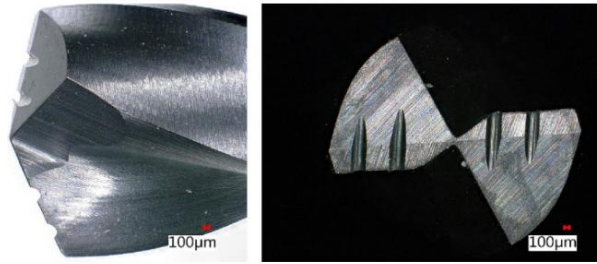

Fig.19. Twist drill with a chip breaker in the form of grooves on both cutting edges [30]

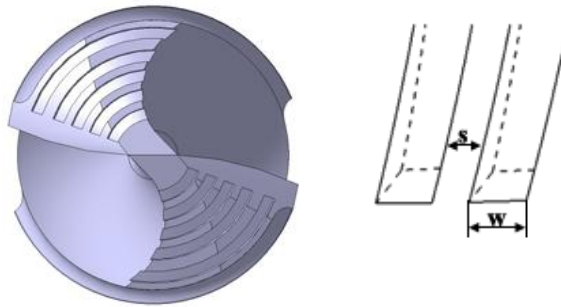

Fig.20. Square micro-texture on the rake face of a twist drill [32]

Wang *et al.* [34] designed a new geometry for a step drill, incorporating a special blocking surface adjacent to the rake face on the second step, which limits lateral chip movement and promotes chip breakage. Studies have shown that this geometry effectively breaks aluminum chips but increases axial force and the surface roughness of the holes. Aisheng Jiang *et al.* [35] proposed a method for optimizing the chip groove in indexable insert drills when drilling deep  $7D$  holes (Fig.21).

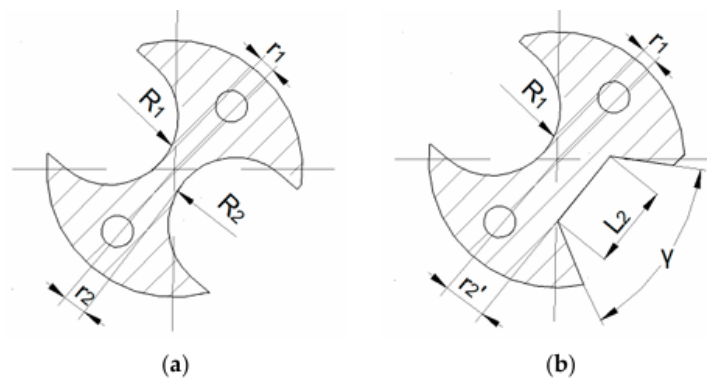

Fig.21. Flute profiles: a) standard  $U$ -profile, b) profile with combined section,  $r_1$  – web thickness of the inner flute,  $r_2$  – web thickness of the outer flute,  $R_1$  – arc radius at the bottom of the inner flute,  $R_2$  – arc radius at the bottom of the outer flute,  $r'_2$  – reduced web thickness of the outer flute,  $L_2$  – width of the bottom of the outer flute with a trapezoidal profile,  $\gamma$  – opening angle of the chip flute,  $46.5^\circ$

Gökçe *et al.* [36] designed a hybrid drill bit incorporating indexable carbide and aluminum inserts, which prevented a sharp increase in blade temperature and reduced the surface roughness of the drilled holes compared to drills made entirely of cemented carbide.

## 8. Conclusions

The paper presents an overview of modern hole machining tool designs. It discusses the fundamental cutting parameters, the main criteria for classifying drills, the design and geometry of drills, and the types of drill sharpening. Currently, cemented carbide drills, three-flute drills, drills with replaceable inserts and tips, and multi-stage drills are commonly used in drilling operations.

It has been found that the quality of the drilling process depends on the drills in terms of both material and design, as well as on the precision of drill manufacturing. The quality of drilling and the selection of appropriate drills also depend on multiple components of the system, including the machine tool, the tool holder, and the machining parameters.

The design of modern drills focuses on: reducing tool wear – cemented carbide drills; reducing hole machining time – three-flute drills; minimizing tool replacement costs – drills with exchangeable tips or indexable inserts; and enabling the machining of multiple diameters in a single operation – step drills.

Cemented carbide drills provide high wear resistance and high-temperature stability but are brittle and costly, making them suitable for hard materials and series production. Three-flute drills enhance material removal rates and improve surface quality, particularly when machining aluminum alloys and stainless steels. Indexable insert drills offer high efficiency and allow rapid replacement of worn elements, making them ideal for deep holes and serial production. Step drills enable the machining of multiple diameters in a single operation, offering high efficiency for thin sheets and composites, though they have limitations in deep-hole drilling.

A comparison of different drill designs and an analysis of the directions of their modifications indicate that these tools are continuously being developed to improve machining parameters, enhance process efficiency, and reduce production costs. The results of numerous studies suggest that further innovations will be pursued to optimize drill geometry, enabling the creation of tools that are best suited to the requirements of a rapidly evolving industry.

## Nomenclature

$d$  – drill diameter [mm]

$f_n$  – feed per revolution [ $mm/rev$ ]

FGM – functionally graded material

HSS – High Speed Steel

HSS-Co – High Speed Steel-Cobalt

$n$  – spindle speed [rpm]

$v_c$  – cutting speed [ $m/min$ ]

$v_f$  – feed rate [ $mm/min$ ]

## References

- [1] Kiyak M. (2025): *A New Mathematical Model to Predict Hole Surface Roughness in Drilling Operations.*– Reports in Mechanical Engineering, vol.6, No.1, pp.24-34, DOI:10.31181/rme407.
- [2] Olszak W. (2008): *Machining.*– PWN, Warsaw (in Polish).
- [3] Astakhov V.P. (2024): *High-Productivity Drilling Tools Design and Geometry.*– CRC Press, Boca Raton
- [4] Cichosz P. (2015): *Cutting Tools.*– WNT, Warsaw (in Polish).
- [5] Feldshtein E. and Leksycki K. (2024): *Selected Issues of High-Performance Machining.*– University of Zielona Góra Press, Zielona Góra (in Polish).
- [6] Cookson C. (2018): *Drilling Technology Latest Bit Designs Drill Faster, Farther.*– American Oil & Gas Reporter, vol.61, No.12, pp.58-63.

- [7] Gühring KG (2025): *Pioneering the Future of Drilling: Modular Drills BT 800 Advantages*.– <https://guehring.com/en/products-drilling-modular-drills-bt800-advantages/> [Accessed: Nov. 13, 2025].
- [8] Sandvik Coromant (2025): *Unlocking the Benefits of Multi-Material Drills*.– <https://www.sandvik.coromant.com/en-us/inside-manufacturing/unlocking-the-benefits-of-multi-material-drills> [Accessed: Nov. 13, 2025].
- [9] Intel Market Research (2025): *Twist Drill Market Growth Analysis, Dynamics, Key Players and Innovations, Outlook and Forecast 2025-2032*.– Intel Market Research, Pune.
- [10] Marlow M.F. (2010): *Machine Shop Know-How*.– Metal Arts Press, Meridian.
- [11] Sandvik Coromant (2017): *Metal Cutting Technology – Technical Guide*.– Sandvik Coromant, Sandviken.
- [12] Pieško P., Woźniak M. and Zawada-Michałowska M. (2018): *Influence of included drill angle on cutting forces during drilling of aluminum alloy*.– *Mechanik*, No.8-9, pp.722-724, DOI:10.17814/mechanik.2018.8-9.105 (in Polish).
- [13] Konfederak M. (2007): *Making Round Holes 722[02].ZI.03 Student's Guide*.– ITE, Radom (in Polish).
- [14] Astakhov V.P. (2010): *Geometry of Single-point Turning Tools and Drills Fundamentals and Practical Applications*.– Springer, Berlin.
- [15] ISCAR Member (2025): *Drilling Handbook ISCAR's Reference Guide*.– IMC Group, Tefen.
- [16] MSK CNC Tools (2025): *8 Features of a Twist Drill and Its Functions*.– <https://www.mskcnc tools.com/pl/news/8-features-of-a-twist-drill-and-its-functions/> [Accessed: Nov. 15, 2025].
- [17] CNC Blog (2025): *Drill bit construction – key information*.– <https://blog-cnc.pl/budowa-wiertlanajwazniejsze-informacje/> [Accessed: Nov. 15, 2025] (in Polish).
- [18] Quickgrind (2023): *Full Range Brochure Solid Carbide Tooling, Drills and Blades The Ultimate in Choice, Quality and Performance*.– Quickgrind, Tewkesbury.
- [19] Dormer Pramet (2025): *Solid Carbide Drill: Optimum Productivity and Reliable Performance*.– <https://dormerpramet.com/uk-ie/en/Solid-carbide-drill-optimum-productivity-and-reliable-performance> [Accessed: Nov. 16, 2025].
- [20] MAPAL (2023): *The Technology Partner for Cost-Effective Machining – Bore Machining*.– MAPAL, Aalen.
- [21] Mejer D. (2024): *The Advantages of 3-Flute Drills Over 2-Flute Drills*.– Production Engineering Solutions, June 2024.
- [22] Tungaloy (2021): *Accelerated Machining*.– Tungaloy, Iwaki.
- [23] Sandvik Coromant (2025): *CoroPak 25.1 New Cutting Tools and Solutions*.– Sandvik Coromant, Sandviken.
- [24] Miller MAPAL Group (2025): *Standard Range Solid Carbide Tools*.– MAPAL, Aalen.
- [25] Darmet (2025): *Fold-out insert drills*.– <https://www.e-darmet.pl/wiertla-plytkowe-skladane> [Accessed: Nov. 16, 2025] (in Polish).
- [26] Sandvik Coromant (2020): *CoroDrill® DS20 What Innovation Looks Like*.– Sandvik Coromant, Sandviken.
- [27] Dormer Pramet (2023): *Holemaking 2023-2024*.– Dormer Pramet, Prague.
- [28] FANAR (2025): *Step Drills*.– Fanar, Ciechanów.
- [29] Delmet (2025): *Step drills*.– <https://delmet.pl/wiertla-stopniowe/> [Accessed: Nov. 16, 2025] (in Polish).
- [30] Pelikan L., Slaný M., Stranský O., Beranek L., Pitrmuc Z., Cepova L. and Dvorackova S. (2023): *Novel drill geometries for dry drilling of stainless steel*.– *Journal of Manufacturing Processes*, vol.94, pp.55-66, DOI:10.1016/j.jmapro.2023.03.006.
- [31] Jeong J., Kurniawan R., Kwak Y.I., Yoon I.C., Ali S. and Ko T.J. (2024): *Helical groove texturing on flutes of twist drill and hole machining enhancement*.– *Journal of Manufacturing Processes*, vol.128, pp.80-92, DOI:10.1016/j.jmapro.2024.08.066.
- [32] Ozturk E. and Kaya K. (2024): *Drilling performance of micro-textured twist drill bit for Ti-6Al-4V alloy: Validated FEM and statistical approaches*.– *Journal of Manufacturing Processes*, vol.115, pp.162-181, DOI:10.1016/j.jmapro.2024.02.023.

- [33] Maldonado-Cortés D., Peña-Parás L., Rodríguez-Villalobos M., Castillo-Barraza A.P. and Cruz-Olace R. (2025): *Increased performance in CNC drilling process through the application of laser surface texturing.*– *Wear*, vol.540-541, Article 205937, DOI:10.1016/j.wear.2025.205937.
- [34] Wang F., Zhao M., Fu R., Yan J., Qiu S. and Hao J. (2021): *Novel chip-breaking structure of step drill for drilling damage reduction on CFRP/Al stack.*– *Journal of Materials Processing Technology*, vol.289, Article 117033, DOI:10.1016/j.jmatprotec.2020.117033.
- [35] Jiang A., Liu Z. and Zhao J. (2024): *A novel design method for chip flute of indexable insert drill used at large drilling depth.*– *Metals*, vol.14, No.12, Article 1351, DOI:10.3390/met14121351.
- [36] Gökçe H. and Çiftçi İ. (2024): *Innovative hybrid drill bit that accelerates heat conduction: Its design, manufacturing and test.*– *Journal of Manufacturing Processes*, vol.119, pp.104-118, DOI:10.1016/j.jmapro.2024.04.006.

Received: January 30, 2026

Revised: May 4, 2026