

Technical note

MOTION ANALYSIS OF THE HYDRAULIC LADDER

P. FRANKOVSKÝ*, I. DELYOVÁ, M. TREBUŇOVÁ, P. ČARÁK and M. KICKO

Department of Mechatronics, Faculty of Mechanical Engineering
Technical University of Košice, Letná 9, 042 00 Košice, SLOVAKIA
E-mail: peter.frankovsky@tuke.sk

P. KURYLO

University of Zielona Góra, Faculty of Mechanical Engineering
Institute of Machine Building and Operation
Zielona Góra, POLAND
E-mail: P.Kurylo@ibem.uz.zgora.pl

This paper is aimed at a dynamic analysis of a hydraulically lifted ladder by means of analytical and numerical calculations. The solutions used in the dynamic analysis of mechanical systems were used in the analytical solution. A numerical model was created to verify the achieved results of the solved mechanical system with simulation of its motion.

Key words: motion, hydraulic lifting ladder, velocity, acceleration.

1. Introduction

For safety at a variety of height work, whether in industry or at home, ladders need to be designed to facilitate and increase worker safety. That is the one of the reasons why it is necessary to modernize the construction because of the ever-increasing demands for safety. It is therefore necessary to know their physical, dynamic and kinematic properties when designing ladders. The aim of the paper is to dynamically analyze the hydraulically lifted mounting ladder, which is necessary for the ladder sizing in order to achieve the best required properties.

2. Analytical solution of mechanisms

In analytical mechanics, relationships sometimes use scalar quantities (work, energy, power, etc.), and these methods are generally more difficult in terms of a mathematical model of mechanical systems than the methods used in vector mechanics that are based directly on Newton's laws.

2.2. Method of reduction weight and force variables

If we want to determine the movement of a mechanical system by dynamic analysis and we know external force effects, we use the method of mass and force quantities. If we want to find out the movement of the system of bodies and the internal forces with coupling reactions under the influence of known force variables, it is preferable to choose the reduction method to solve the problem of dynamic body systems. In

* To whom correspondence should be addressed

this case, we reduce the force and mass quantities to a particular rotating member or to a point of a particular member. If we reduce to the point of member, it is a reduction to the sliding member. [1]

If we reduce the mass quantities of moving mechanical systems with one degree of freedom, the kinetic energy of the system after reduction is equal to the kinetic energy of all members of the system. If we reduce to a point, the movement of the entire mechanical system is expressed as the motion of the reduced weight at the point of reduction. By reducing to a rotating member, we replace the motion of the system by moving the rotating member with reduced moment of inertia I_{red} . [2]

2.2.1. Reduction to a point

Each member in a planar mechanical system can perform general planar motion, rotational motion, or translational motion. All members that will perform the sliding motion are denoted by the index i , and their number n_p . The index j denotes the members that perform the rotational motion, their number is denoted by n_r , and the members that perform the general planar motion are denoted by the index k and the number n_o . For all members of the system it is valid that the kinetic energy is

$$E_k = \frac{I}{2} \left[\sum_{i=1}^{n_p} m_i v_i^2 + \sum_{j=1}^{n_r} I_j \omega_j^2 + \sum_{k=1}^{n_o} (m_k v_{Tk}^2 + I_{Tk} \omega_k^2) \right], \quad (2.1)$$

m_i, m_k - the mass of the system members, wherein the displacement member is denoted by i , and the member that performs the general plane motion, the index k ,

I_j, I_{Tk} - moments of inertia, where a system member with index j performs a rotational motion to the axis of rotation and a member with index T_k , performs a general planar motion to the axis of rotation passing through the center of gravity,

v_i - the speed of the i -th member of the system performing the sliding movement,

T_k - the velocity of the center of gravity of the k -th member of the system that performs a general planar motion,

ω_j - the angular velocity of the j -th member of the system that performs the rotational motion,

ω_k - the angular velocity of the k -th member of the system that performs a rotational motion about the axis passing through the center of gravity. [3]

For the reduced mass concentrated at the reduction point, the kinetic energy is

$$E_{kred} = \frac{I}{2} m_{red} v^2, \quad (2.2)$$

v - reduction point speed,

m_{red} - reduced weight, which is concentrated at the point of reduction.

We can write

$$E_k = E_{kred}. \quad (2.3)$$

By substituting Eqs (2.1) and (2.2) to Eq.(2.3), we will define m_{red}

$$m_{red} = \sum_{i=1}^{n_p} m_i \left(\frac{v_i}{v} \right)^2 + \sum_{j=1}^{n_r} I_j \left(\frac{\omega_j}{\omega} \right)^2 + \sum_{k=1}^{n_o} \left[m_k \left(\frac{v_{Tk}}{v} \right)^2 + I_{Tk} \left(\frac{\omega_k}{\omega} \right)^2 \right]. \quad (2.4)$$

From the point of view of inertia, the entire mechanical system will be equally replaced by a reduced weight m_{red} . [4] [5]

2.2.2. Reduction to rotating member

If we replace the motion of the entire mechanical system with the rotational motion of a member with reduced torque I_{red} , its kinetic energy will be

$$E_{kred} = \frac{I}{2} I_{red} \omega^2. \quad (2.5)$$

We substitute Eq.(2.5) to Eq.(2.4), if E_k is determined by Eq.(2.1) and it will be after the subsequent modification equal to

$$I_{red} = \sum_{i=1}^{n_p} m_i \left(\frac{v_i}{\omega} \right)^2 + \sum_{j=1}^{n_r} I_j \left(\frac{\omega_j}{\omega} \right)^2 + \sum_{k=1}^{n_o} \left[m_k \left(\frac{v_{Tk}}{\omega} \right)^2 + I_{Tk} \left(\frac{\omega_k}{\omega} \right)^2 \right]. \quad (2.6)$$

The same conclusions are valid also for I_{red} . [6][7][8]

2.2.3. Reduction of power quantities

The basis of the reduction method is to replace the movement of the mechanical system. This movement can be replaced by a reduced weight motion that is concentrated at a certain point and reduced by the force F_{red} , or by the rotational movement of the member, with the moment of inertia to the axis of rotation I_{red} to which the reduced torque M_{red} acts. [8][9][10]

We will determine the reduced force F_{red} from the relationship

$$F_{red} \cdot ds = dA, \quad (2.7)$$

ds - vector of the elementary displacement of the reduction point,

dA - the resulting elemental work of external force effects, which is needed to elementally change the position of the system.

The instantaneous powers of the reduced force are equal to the force effects that affect each member of the system

$$F_{red} \cdot v = P, \quad (2.8)$$

P - the resulting instantaneous external force effects,

v - is the speed of the reduction point.

If we reduce it to a rotating member, the size of the reduced torque M_{red} is determined similarly. We can write

$$M_{red} \cdot d\varphi = dA, \quad (2.9)$$

$d\varphi$ - vector of elementary rotation of a rotating member.

Equal immediate performance

$$M_{red} \cdot \omega = P, \quad (2.10)$$

where ω - angular velocity of the rotating member, motion equation for a moving mechanical system with one degree of freedom.

We can write

$$dE_k = dA, \quad (2.11)$$

dE_k - change of kinetic energy in elementary change of system position,

dA - work of external force effects in elementary change of system position.

If we assume that the direction F_{red} is identical with the direction v , after adjusting Eqs (2.2), (2.3), (2.7) we get

$$\frac{d}{ds} \left(\frac{1}{2} m_{red} v^2 \right) = F_{red}. \quad (2.12)$$

By derivation of the left side of the equation we get

$$m_{red} a + \frac{1}{2} \frac{dm_{red}}{ds} v^2 = F_{red}, \quad (2.13)$$

a - acceleration of the reduction point.

The reduced mass, in a constant gear system, is a constant quantity; it is not dependent on the instantaneous position of the system. [11]

The equation of motion (2.13) is in this case

$$m_{red} a = F_{red}. \quad (2.14)$$

If we solve the mechanical system by reducing it to a rotating member and we assume that the directions M_{red} and ω are identical, then by substitution into Eq.(2.11) we get

$$\frac{d}{d\varphi} \left(\frac{1}{2} I_{red} \omega^2 \right) = M_{red}. \quad (2.15)$$

We differentiate the left side of Eq.(2.15) and we get

$$I_{red} \alpha + \frac{1}{2} \frac{dI_{red}}{d\varphi} \omega^2 = M_{red}, \quad (2.16)$$

α - the angular acceleration of the rotating member.

In a constant gear system, the motion equation becomes

$$I_{red}\alpha = M_{red} \cdot \tag{2.17}$$

The previous equations also are valid in systems where passive resistances are considered. To calculate frictional forces and force pairs, we need to know the binding reactions. These are usually determined by the release method. We cannot accurately analyze the amount of passive resistance; therefore we do not usually consider them in specific examples using the reduction method. [2][12][13][14]

If we use the reduction method for mechanical systems with elastic bonds, we must use reduced system stiffness in the reduction to the shifting member, and use the reduced torsional stiffness of the system by reduction to the rotating member. [15][16][17]
 The reduced stiffness is determined from the equation

$$E_{pred} = E_p \cdot \tag{2.18}$$

3. An analytical solution of ladder design

The ladder is lifted from the initial position determined by points A_0, B_0 to the working position (Fig.1). The method of reduction to a rotating member will assemble the motion equation of the examined system if a constant force F is applied to the piston of the hydraulic cylinder. The body of ladder 2 is guided by pulleys at points A and B, which roll in horizontal and vertical plane. We do not consider passive resistances.

The solution is given by geometric and mass quantities

$$m_2, m_3, m_4, m_5, l_{2S2}, l_{3A}, l_{4B}, r, l, l_{S2}, L, F = const.$$

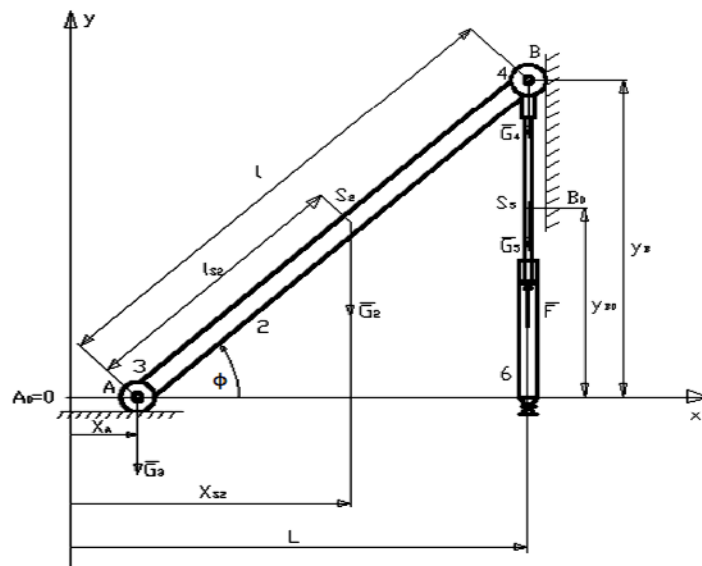

Fig.1. Diagram of a hydraulically lifted ladder.

This is a planar system with 1 degree of freedom with variable gear

$$n = 3(m - 1) - 2(r + \gamma + v) - o. \tag{3.1}$$

Substituting we got

$$n = 3(6 - 1) - 2(4 + 1 + 2) = 15 - 14 = 1^\circ \tag{3.2}$$

There is 1 independent coordinate that uniquely determines the position of the mechanism.

Select: $q \equiv \varphi$ - angle of mounting ladder

Subsequently, the necessary lifting dependencies

$$\begin{aligned}x_A &= L - l \cos \varphi & \Rightarrow \dot{x}_A &= l \sin \varphi \dot{\varphi}, \\x_{S_2} &= L - (l - l_{S_2}) \cos \varphi & \Rightarrow \dot{x}_S &= (l - l_{S_2}) \sin \varphi \dot{\varphi}, \\y_{S_2} &= l_{S_2} \sin \varphi & \Rightarrow \dot{y}_S &= l_{S_2} \cos \varphi \dot{\varphi}, \\y_B &= l \sin \varphi & \Rightarrow \dot{y}_B &= l \cos \varphi \dot{\varphi}, \\x_A &= r \psi_3 & \Rightarrow \dot{\psi}_3 &= \frac{\dot{x}_A}{r} \equiv \frac{l}{r} \sin \varphi \dot{\varphi}, \\y_B - y_{B_0} &= r \psi_4 & \Rightarrow \dot{\psi}_4 &= \frac{\dot{x}_A - \dot{y}_B}{r} \equiv \frac{l}{r} \cos \varphi \dot{\varphi}, \\ \dot{y}_B &\equiv 0,\end{aligned}$$

where

x_A - distance of point A in the x -axis direction,

x_{A_0} - distance of point A_0 in the x -axis direction,

x_{S_2} - the center of gravity of body 2 in the x -axis direction,

y_{S_2} - the center of gravity of body 2 in the y -axis direction,

y_B - distance of point B in the y -direction,

y_{B_0} - distance of point B_0 in the y -direction.

Reduce the system to a fictitious rotating member. The total kinetic energy of the system is given by the kinetic energy of bodies 2, 3, 4 acting on the general plane motion and bodies 5 acting on the sliding motion. [18][19][20]

The following applies

$$\begin{aligned}E_k &= \frac{1}{2} I_{red} \dot{\varphi}^2 = \frac{1}{2} m_2 (\dot{x}_{S_2}^2 + \dot{y}_{S_2}^2) + \frac{1}{2} I_{2S_2} \dot{\varphi}^2 + \frac{1}{2} m_3 \dot{x}_A^2 + \\ &+ \frac{1}{2} I_{3A} \dot{\psi}_3^2 + \frac{1}{2} m_4 \dot{y}_B^2 + \frac{1}{2} I_{4B} \dot{\psi}_4^2 + \frac{1}{2} m_5 \dot{y}_B^2.\end{aligned}\tag{3.3}$$

Adjusting we get

$$\begin{aligned}& \frac{1}{2} m_2 \left[(l - l_{S_2})^2 \sin^2 \varphi + l_{S_2}^2 \cos^2 \varphi \right] \dot{\varphi}^2 + \frac{1}{2} I_{2S_2} \dot{\varphi}^2 + \frac{1}{2} m_3 l^2 \sin^2 \varphi \dot{\varphi}^2 + \\ & + \frac{1}{2} I_{3A} \left(\frac{l}{r} \right)^2 \sin^2 \varphi \dot{\varphi}^2 + \frac{1}{2} m_4 l^2 \cos^2 \varphi \dot{\varphi}^2 + \frac{1}{2} I_{4B} \left(\frac{l}{r} \right)^2 \cos^2 \varphi \dot{\varphi}^2 + \frac{1}{2} m_5 l^2 \cos^2 \varphi \dot{\varphi}^2 = \\ & = \frac{1}{2} \left[I_{2S_2} + \left(m_2 \frac{(l - l_{S_2})^2}{l^2} + m_3 + \frac{I_{3A}}{r^2} \right) l^2 \sin^2 \varphi + \left(m_2 \left(\frac{l_{S_2}}{l} \right)^2 + m_4 + m_5 + \frac{I_{4B}}{r^2} \right) l^2 \cos^2 \varphi \right] \dot{\varphi}^2.\end{aligned}$$

Introducing

$$A = m_2(l - l_{S2})^2 + \left(m_3 + \frac{I_{3A}}{r^2}\right)l^2,$$

$$B = m_2l_{S2}^2 + \left(m_4 + m_5 + \frac{I_{4B}}{r^2}\right)l^2,$$

the following applies

$$E_k = \frac{1}{2}I_{red}(\varphi)\dot{\varphi}^2 = \frac{1}{2}(I_{2S2} + A\sin^2\varphi + B\cos^2\varphi)\dot{\varphi}^2, \quad (3.4)$$

$$I_{red}(\varphi) = I_{2S2} + A\sin^2\varphi + B\cos^2\varphi.$$

The workforce and force pair are given as

$$P = M_{red}(\varphi)\dot{\varphi} = F\dot{y}_B - m_5g\dot{y}_B - m_2g\dot{y}_{S2} = [F - (m_4 + m_5)g]l\cos\varphi\dot{\varphi} - m_2\cos\varphi\dot{\varphi}, \quad (3.5)$$

$$M_{red}(\varphi) = [(F - (m_4 + m_5)g)l - m_2gl_{S2}]\cos\varphi,$$

$$\frac{dE_k}{dt} = P \Rightarrow \frac{1}{2}\frac{dI_{red}(\varphi)}{d\varphi}\dot{\varphi}^3 + I_{red}(\varphi)\dot{\varphi}\ddot{\varphi} = M_{red}(\varphi)\dot{\varphi},$$

$$I_{red}(\varphi)\ddot{\varphi} + \frac{1}{2}\frac{dI_{red}(\varphi)}{d\varphi}\dot{\varphi}^2 = M_{red}(\varphi). \quad (3.6)$$

We substitute Eqs (3.3) and (3.4) [7][16][21]

$$\frac{dI_{red}(\varphi)}{d\varphi} = 2A\sin\varphi\cos\varphi - 2B\cos\varphi\sin\varphi = 2(A - B)\sin\varphi\cos\varphi, \quad (3.7)$$

$$(I_{2S2} + A\sin^2\varphi + B\cos^2\varphi)\ddot{\varphi} + (A - B)\sin\varphi\cos\varphi\dot{\varphi}^2 = [(F - m_4g - m_5g)l - m_2gl_{S2}]\cos\varphi.$$

4. Dynamic analysis using MSC Adams

After the model was made, simulations of the movement of the hydraulically lifted ladder and the detected physical quantities of the designated members of the system were performed. Quantities that were detected, the more accurate trajectory, the speed, and the acceleration were determined in the pulleys mounted at both ends of the ladder (Fig.2).

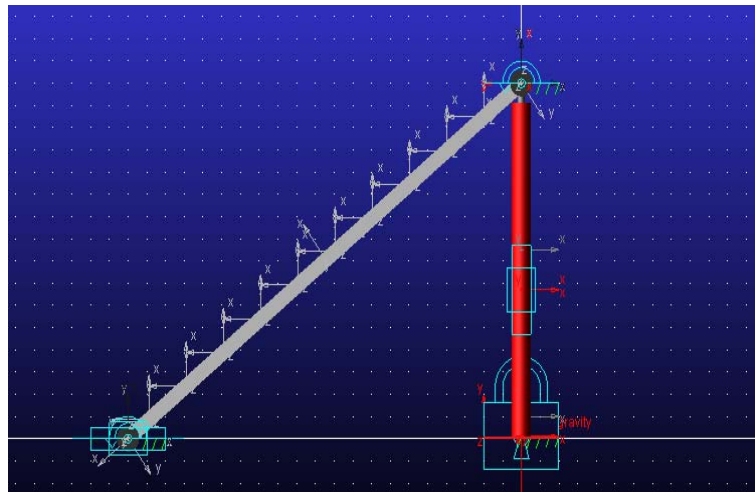

Fig.2. Hydraulic lifting ladder and boundary conditions.

Subsequently, these results were processed in Postprocessor with which were generated the trajectory, velocity and acceleration graphs of the examined system members. These results are shown in Figs 3, 4, 5.

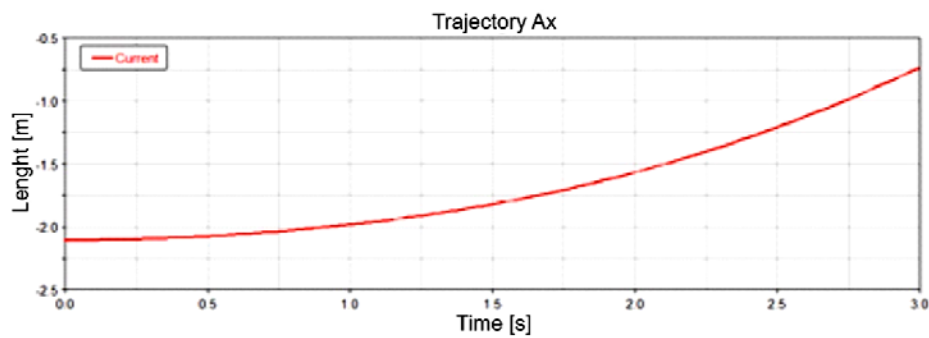

Fig.3. Graphic course of the path of pulley A versus time.

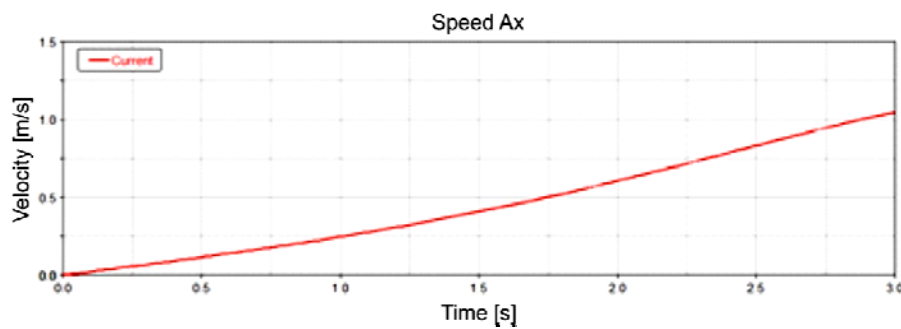

Fig.4. Graphic course of the speed of pulley A versus time.

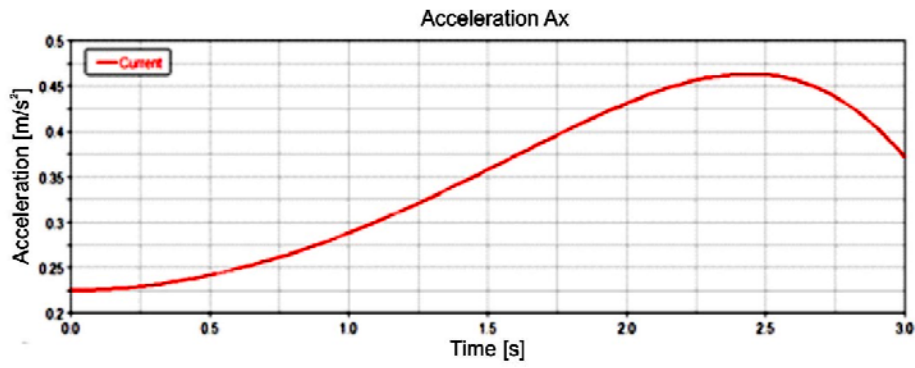

Fig.5. Graphic course of the acceleration of pulley A versus time.

From the Postprocessor we have obtained the required quantities for the pulley located at the top of the ladder. The following figures (Fig.6, Fig.7, Fig.8) show the graphic trajectory, speed and acceleration versus time

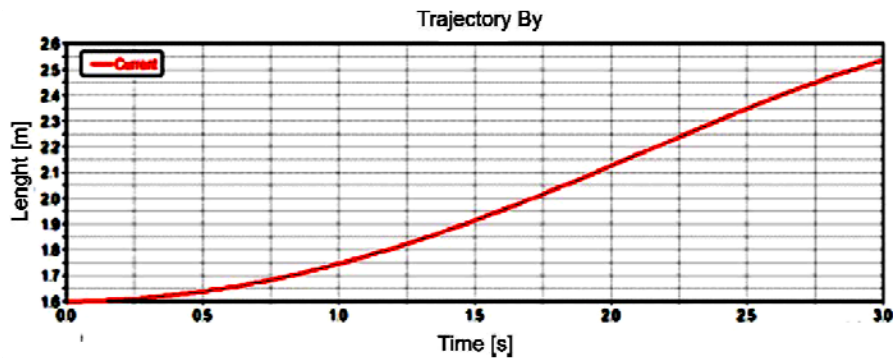

Fig.6. Graphic course of the path of pulley B versus time.

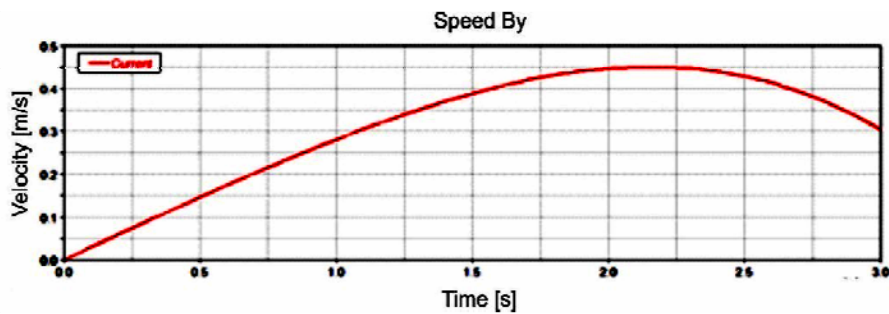

Fig.7. Graphic course of the speed of pulley B versus time.

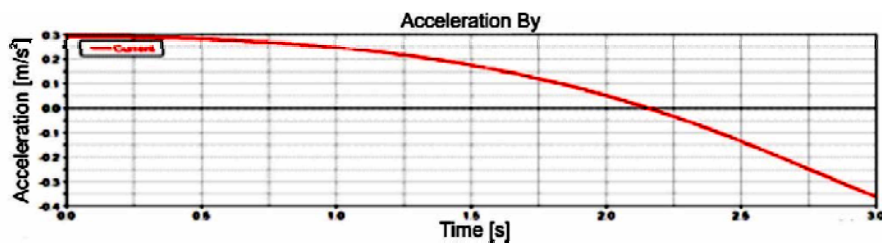

Fig.8. Graphic course of the acceleration of pulley B versus time.

5. Conclusion

We do not consider passive resistances in the solution and therefore we are unable to determine exactly whether these values would be accurate in the real mechanism. If the output values of the trajectory, speeds, and accelerations were appropriate, the design of the hydraulic ladder could be used in practice, at different heights, but since we were dealing with a simplified ladder model, modifications to the mechanical system would still be necessary. The advantage of this hydraulically lifted ladder is its relatively simple construction compared to multi-section ladders whose construction is complex.

Acknowledgements

The work was supported by the grant projects VEGA No. 1/0290/18, VEGA No. 1/0731/16, KEGA 069TUKE-4/2017 and APVV-17-0258.

M.R.D., K.K.D., W.W. acknowledge the financial support from the program of the Polish Minister of Science and Higher Education under the name "Regional Initiative of Excellence" in 2019 - 2022, project no. 003/RID/2018/19, funding amount 11 936 596.10 PLN.

References

- [1] Waldron K.J., Kinzel G.L. and Aggrawal S.K. (2016): *Kinematics, dynamics, and design of machinery*. – John Wiley and Sons.
- [2] Dwivedy S.K. and Eberhard P. (2006): *Dynamic analysis of flexible manipulators*, a literature review. – *Mechan. Mach. Theory*, vol.41, No.7, pp.749–777.
- [3] Shabana A.A. (1998): *Dynamics of Multibody Systems*. – Cambridge University Press.
- [4] Pivarčiová E., Božek P., Turygin Y., Zajačko I., Shchenyatsky A., Václav Š. and Gemela B. (2018): *Analysis of control and correction options of mobile robot trajectory by an inertial navigation system*. – *International Journal of Advanced Robotic Systems*, vol.15, No.1, 1729881418755165.
- [5] Vavro Jr. J., Vavro J., Kováčiková P. and Bezdedová R. (2016): *Kinematic and dynamic analysis of the manipulator for removal of rough tyres*. – *ProcediaEngineering*, vol.136, pp.120-124.
- [6] Vavro Jr. J., Vavro J., Kováčiková P. and Bezdedová R. (2017): *Kinematic and dynamic analysis of planar mechanisms by means of the solid works software*. – *ProcediaEngineering*, vol.177, pp.476-481.
- [7] Tlach V., Císar M., Kuric I. and Zajačko I. (2017): *Determination of the industrial robot positioning performance*. – In *MATEC Web of Conferences* (vol.137, p. 01004). EDPSciences.
- [8] Morgül Ö. (1991): *Orientation and stabilization of a flexible beam attached to a rigid body: Planar motion*. – *IEEE Trans. Autom. Control*, vol.36, No.8, pp.953–962.
- [9] Yuan Q., Lew J. and Piyabongkarn D. (2009): *Motion control of an aerial work platform*. – In *Proc. Amer. Control Conf. (ACC)*, pp.2873–2878.
- [10] Matthies H.J. (1991): *Einführung in die Ölhydraulik*. – Teubner Studienbücher, Stuttgart.
- [11] Conrad F. and Morgül Ö. (1998): *On the stabilization of a flexible beam with a tip mass*. – *SIAM J. Control Opt.*, vol.36, No.6, pp.1962–1986.
- [12] Turygin Y., Božek P., Nikitin Y., Sosnovich E. and Abramov A. (2016): *Enhancing the reliability of mobile robots control process via reverse validation*. – *International Journal of Advanced Robotic Systems*, vol.13, No.6, 1729881416680521.
- [13] Hagemeyer V. and Delaleau E. (2003): *Exact feed forward linearization based on differential flatness*. – *Int. J. Control*, vol.76, No.6, pp.537–556.
- [14] Aschemann H., Sawodny O., Bulach A. and Hofer E. (2002): *Model based trajectory control of a flexible truntable ladder*. – In *Proc. Amer. Control Conf.*, vol.2, pp.921–926.

- [15] Walicka A., Jurczak P. and Walicki E. (2010): *Inertia effects in a curvilinear thrust hydrostatic bearing with a porous pad*. – International Journal of Applied Mechanics and Engineering, vol.15, No.4, pp.1227-1238.
- [16] Singhose W.E., Singer N.C., Derezinski III S.J., Rappole Jr. B.W. and Pasch K. (1997): *Method and apparatus for minimizing unwanted dynamics in a physical system*. – U.S. 5, 638 267.
- [17] Sira-Ramirez H. and Agrawal S. (2004): *Differentially Flat Systems*, ser. Control Engineering Series. New York: Marcel Dekker.
- [18] Kuric I., Bulej V., Saga M. and Pokorny P. (2017): *Development of simulation software for mobile robot path planning with in multilayer map system based on metric and topological maps*. – International Journal of Advanced Robotic Systems, vol.14, No.6, 1729881417743029.
- [19] Saga M. and Jakubovicova L. (2014): *Simulation of vertical vehicle non-stationary random vibrations considering various speeds*. – Scientific Journal of Silesian University of Technology – Series Transport, vol.84, pp.113-118.
- [20] Kuryło P., Pivarčiová E., Cyganiuk J. and Frankovský P. (2019): *Machine vision system measuring the trajectory of upper limb motion applying the matlab software*. – Measurement Science Review, vol.19, No.1, pp.1-8.
- [21] Martins J., da Costa J.S. and Botto M. (2005). *Advances in computational multibody systems*, ser. Computational Methods in Applied Sciences. The Netherlands: Springer, vol.2, ch. Modelling, Control and Validation of Flexible Robot Manipulators, pp.239–268.

Received: May 31, 2019

Revised: June 25, 2019